



**USER
MANUAL**



**SYSTEM
HYDROSMART BASIC**





USER MANUAL

HYDROSMART BASIC



Hydro
SMART Basic

EN

Translated version

Edition: 10/2025

Revision level: 03

Document code: ZMNW014-EN



© ADR - All rights reserved.

The contents of this manual, including text, graphics, photographs, and other materials, are protected by applicable copyright and intellectual property laws. They belong exclusively to the ADR group.

Reproducing, copying, distributing, modifying, publishing, transmitting, or disseminating the contents of this manual, in whole or in part, is prohibited without the express written permission of the owner.

Contents

1	Information.....	4
1.1	General information	4
1.2	Warranty conditions	4
1.3	Symbols and terms used in the manual	5
1.4	Suggestions for your safety	5
1.4.1	General rules.....	5
1.4.2	Safety.....	7
1.5	Product identification data	8
1.5.1	Axle identification plate	8
1.5.2	Product identification plate reading.....	9
2	Introduction.....	10
2.1	HYDROSMART BASIC description.....	10
2.2	Applicability.....	11
3	Functioning of the system	12
3.1	General	12
3.2	Normal (mode RUN).....	12
3.3	Lifting of the axle (mode AXLE LIFT)	13
3.4	Leveling of the whole suspension (mode LEVELING)	14
3.5	Locking of the axles while tipping (only for version 9ZH1E0SA004).....	14
4	Hydraulic diagrams.....	15
4.1	Version 9ZH1E0SA003	15
4.1.1	Tandem 9ZH1E0SA003-C.....	16
4.1.2	Tridem 9ZH1E0SA003-E	17
4.2	Version 9ZH1E0SA004 (with rear axles locking function).....	18
4.2.1	Tandem 9ZH1E0SA004-C.....	19
4.2.2	Tridem 9ZH1E0SA004-E	20



1 Information

1.1 General information

This manual contains the main maintenance information applicable to ADR HYDROSMART BASIC System.

This manual should be kept with care.

In the event damages makes the copy of this manual in your possession unusable, the user can request a copy from customer service, specifying the type of product and serial number indicated on the product identification plate. Please contact customer service for information on updates ADR has made to its products. In any event, the latest version of this manual can be found in the *download* section on site www.adraxles.com.

ADR SPA
Customer service
Tel: +39 02 9617 11
Fax: +39 02 9617 1420
E-mail: customer care@adraxles.com

ADR cannot be held liable for damages caused by:

- improper product use;
- use by unqualified and/or unskilled personnel;
- incorrect installation (if by the customer);
- inadequate product maintenance or cleaning;
- unauthorised alterations or work;
- incorrect manoeuvres;
- use of non-original spare parts;
- use of unforeseen accessories or not authorised in writing;
- full or partial failure to follow the instructions;
- exceptional events.

1.2 Warranty conditions

As a memorandum for the user, ADR guarantees the technical specifications, part quality and good supplied product operations according to the stated parameters.

The manufacturer's warranty does not cover all parts whose repair or replacement is due to natural part wear or defects due to incorrect product use by the customer such as, for example but not limited to:





- unauthorised alterations;
- use other than that indicated by ADR;
- product overloads beyond that indicated by ADR;
- negligent or poor product part maintenance;
- work on products inconsistent with ADR instructions;
- failure to replace parts subject to wear, etc.

Please remember that every alteration to the vehicle voids original approval and requires new approval or forfeit the vehicle registration card until standardised.

In the event product defects are found, the customer must communicate them in writing.

This manual was originally drafted in Italian, and it is the only official language for which the manufacturer is liable in the event of translation inconsistencies.

1.3 Symbols and terms used in the manual

	<p>Warning</p> <p>Indicates instructions that only if correctly followed avoid personal hazard situations, provides information on hazards and how to avoid them, suggests performance procedures.</p>
	<p>Attention to tightening torque</p> <p>Indicates the tightening torque values to be applied to certain products to avoid personal hazard situations, potential inefficiencies and product break downs.</p>
	<p>Wrench</p> <p>Indicates ordinary and scheduled maintenance procedures to be performed in safe conditions. These must be performed by an authorised individual trained for this purpose.</p>
	<p>Lubricant grease</p> <p>Indicates ordinary and scheduled greasing procedures (lubrication with grease) to be performed in safe conditions. These must be performed by an authorised individual trained for this purpose.</p>
	<p>ADR customer service</p> <p>Indicates the need to contact ADR customer service. In the event of particularly important part maintenance to guarantee normal product operations, contact ADR to set a service appointment on the customer's premises.</p>

1.4 Suggestions for your safety

1.4.1 General rules

Vehicle repairs and maintenance may expose operators to unforeseen problems. This warning only illustrates some potential hazards, and its purpose is to make users aware of risks that may occur and guide them towards reasonable behaviour to promote safety.

ADR recommends having maintenance performed by specialised departments.

Important: Never overload your vehicle. The chassis, axles and brakes may suffer damages.

Never exceed the total vehicle weight admitted by the manufacturer, nor the maximum speed set by circulation rules. Your vehicle will thus operate in maximum safety, will always brake efficiently and reliably even on long descents. Tyre wear will be even and driving stability with many curves will always be ensured.

Place the load to evenly distribute the load on all wheels as much as possible. This achieves higher and safer driving performance; longer lasting tyres and the tractor will save fuel.

Only use tyres of the type and size indicated by the vehicle manufacturer according to axle design requirements. The use of wheels with disc offset must be authorised by the manufacturer. Constantly check braking system efficiency, periodically checking brake gasket wear, lever regulation and control cylinder conditions.



Personal protection: Wear all the equipment and protections necessary: goggles, masks, gloves, helmets, safety shoes, protective clothing, etc.; Work in pairs of two.

Unstable vehicles: Never work under or near a vehicle that was only lifted by a jack. When working under or near a lifted vehicle, always make sure the jack used is associated with supports or suitable blocks and that the material used is suited to the lifted load. Make sure the group is perfectly stable and that it will remain so during and after the forces applied to the material during maintenance. Also ensure ground stability.

Hot parts: Be careful of parts that may become very hot during use such as, for example, brake drums.

Pressurised, hydraulic, or pneumatic circuit: before working on the hydraulic or pneumatic circuit, oil and air may be pressurised, take all the necessary precautions to avoid accidental jets.

Risks due to fires, tied to smoke, toxic gas and irritant substances: All fuels are highly flammable and mix vapours explosive. To clean or degrease parts, only use retail products suited for this purpose and follow the instructions on the packaging. Never put these products into contact with skin and never inhale vapours, smoke, or gas.

WARNING: Smoking, the use of flames, producing sparks, etc. causes **explosion or fire hazards** due to vapours, fuels, oils, paints, solvents, dust, straw, etc.; keep an extinguisher at hand at the work site to meet these risks.

Asbestos: Our axle brake gaskets no longer contain asbestos and this long before European community provisions banned its use. In the event of doubt on asbestos (working on old material for example), handle parts as if they contained it, asbestos dust is extremely hazardous to health.

Ecology: Much care and focus were placed on the analysis of the negative effects of our products' impact on the environment. Similarly, do not discard oil, grease and used products in the environment, respect nature and the rules. Discard them at a collection point, dump, or recycling area. To receive the address of your nearest point, contact your local environmental service agency.

1.4.2 Safety

Observe the following safety measures before, during and after use. By following these measures and using common sense, injury to persons and damage to the equipment can be avoided.

Read this manual and the safety measures before operating the equipment.

Make sure that all safety devices are properly attached before operating the equipment.

Check that there are no personnel around the equipment, before or during operation (minimum 6 m).

Do not overload the equipment. Respect the load limits.

Make sure the hitch sensor is securely attached to the vehicle according to the instructions in this manual.

Before starting the machine, check the safety of the machine at work and in traffic each time.

Before starting the machine, familiarize yourself with all drive elements and their operation.

Before working on the hydraulic system, remove the pressure from the corresponding circuit, stop the engine and switch off the equipment.

Under normal conditions, pipes and hoses in hydraulic circuits undergo a natural aging process.

The service life of these elements should not exceed 6 years. Periodically observe their condition and replace them after this time.

Be prepared in case of fire. Keep a first aid kit and a fire extinguisher handy.



1.5 Product identification data

Product identification data is indicated on a specific **identification plate**, affixed or riveted to the product. Each **identification plate**, for both axle, suspension, and drawbar identification, indicates the items illustrated below.

1.5.1 Axle identification plate

The typologies ID plate of the product found on ADR axles are visible in the following pictures.

Metallic ID plate

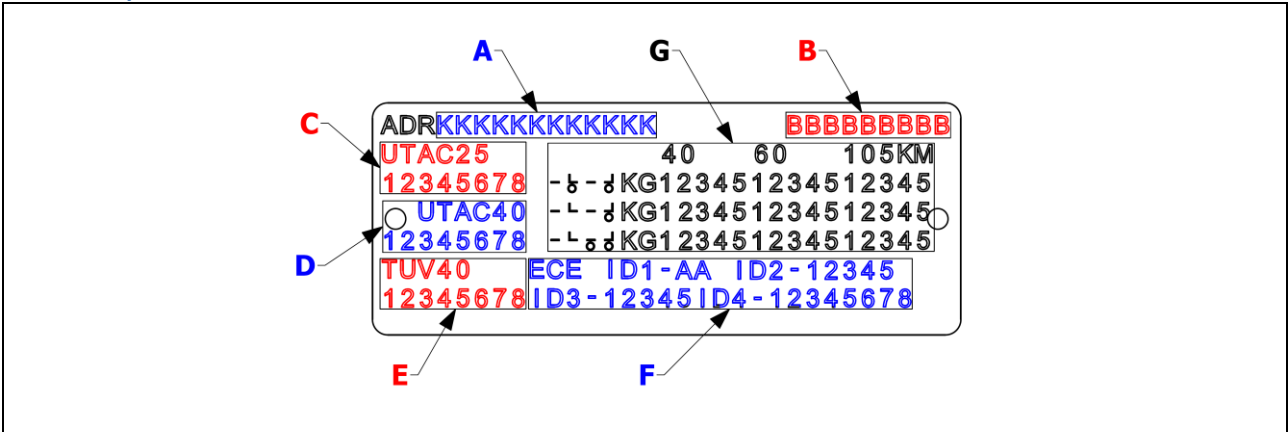

Adhesive ID plate

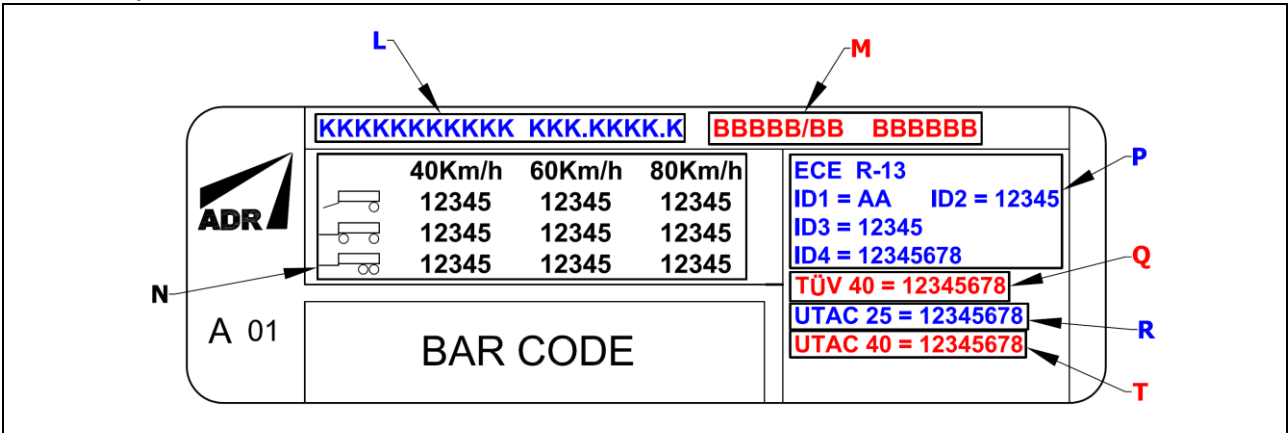

1.5.2 Product identification plate reading

The **axle identification plate** can be read as follows:

- **A** : axle identification code, the code is made up of 12 alphanumeric characters;
- **B** : order identification code, the code is made up of 9 alphanumeric characters;
- **C** : UTAC approval report identification code at 25 km/h, the code is made up of 8 characters;
- **D** : UTAC approval report identification code at 40 km/h, the code is made up of 8 characters;
- **E** : StVZO approval report identification code at 40 km/h, the code is made up of 8 characters;
- **F** : ECE-R13 or EU 2015/68 approval identification data;
- **G** : maximum axle capacity data referred to the application and speed.

The adhesive ID plate in the case of an axle, instead, can be read as follows:

- **L** : axle code;
- **M** : customer code;
- **N** : carrying capacity of the axle;
- **P** : **ECE-R13** test report data or **EU 2015/68** test report data;
- **Q** : StVZO at 40 km/h test report data;
- **R** : UTAC at 25 km/h test report data;
- **T** : UTAC at 40 km/h test report data.

Data on identification plates are indelible or silk screened.

N.B. the data on the plate cannot be ALTERED for any reason.



2 Introduction

2.1 HYDROSMART BASIC description

HYDROSMART BASIC is the electrohydraulic system for the hydraulic suspension management. It is available in the versions described below:

- 9ZH1E0SA003
It allows an easy and parallel lifting and lowering of the suspension.
It allows to lift the first axle of the trailer
- 9ZH1E0SA004
In addition to system 9ZH1E0SA003 it allows to lock the rear axles while tipping.



The operations for controlling the suspension are carried directly from inside the cab by using the 3-position selector on the hydraulic distributor control on board the tractor.

The systems make it possible to:

- adjust the suspension's ride height. The ideal operating condition for the modules is with the cylinders at half stroke;
- raise the first axle, in order to shift part of the load onto the eye and to gain traction on the tractor's wheels in difficult situations;
- lock automatically the two rear axles while lifting the box on dumper trailers (only version 9ZH1E0SA004).

2.2 Applicability

Applicable only to suspension HYDROCOMPACT with cylinders 100-60 mm diameter:

Code	Description	Application	
9ZH1E0SA003	HYDROSMART BASIC with front axle lift	HydroCompact	
9ZH1E0SA004	HYDROSMART BASIC with front axle lift and rear axles blocking	HydroCompact	

3 Functioning of the system

Observe the following safety measures before, during and after use. By following these measures and with common sense, injury to persons and damage to equipment can be avoided.

3.1 General

The functioning of the system is managed by a controller with a 3-positions switch and a button to be installed in the tractor (button only on version V2).



Never drive with the controller button pressed.
All adjustment must be carried out with the machine stopped

It is recommended to keep oil contamination of the hydraulic circuit below level ISO 4406 18/16/13

3.2 Normal (mode RUN)

The electric switch is positioned in the center, position "RUN".

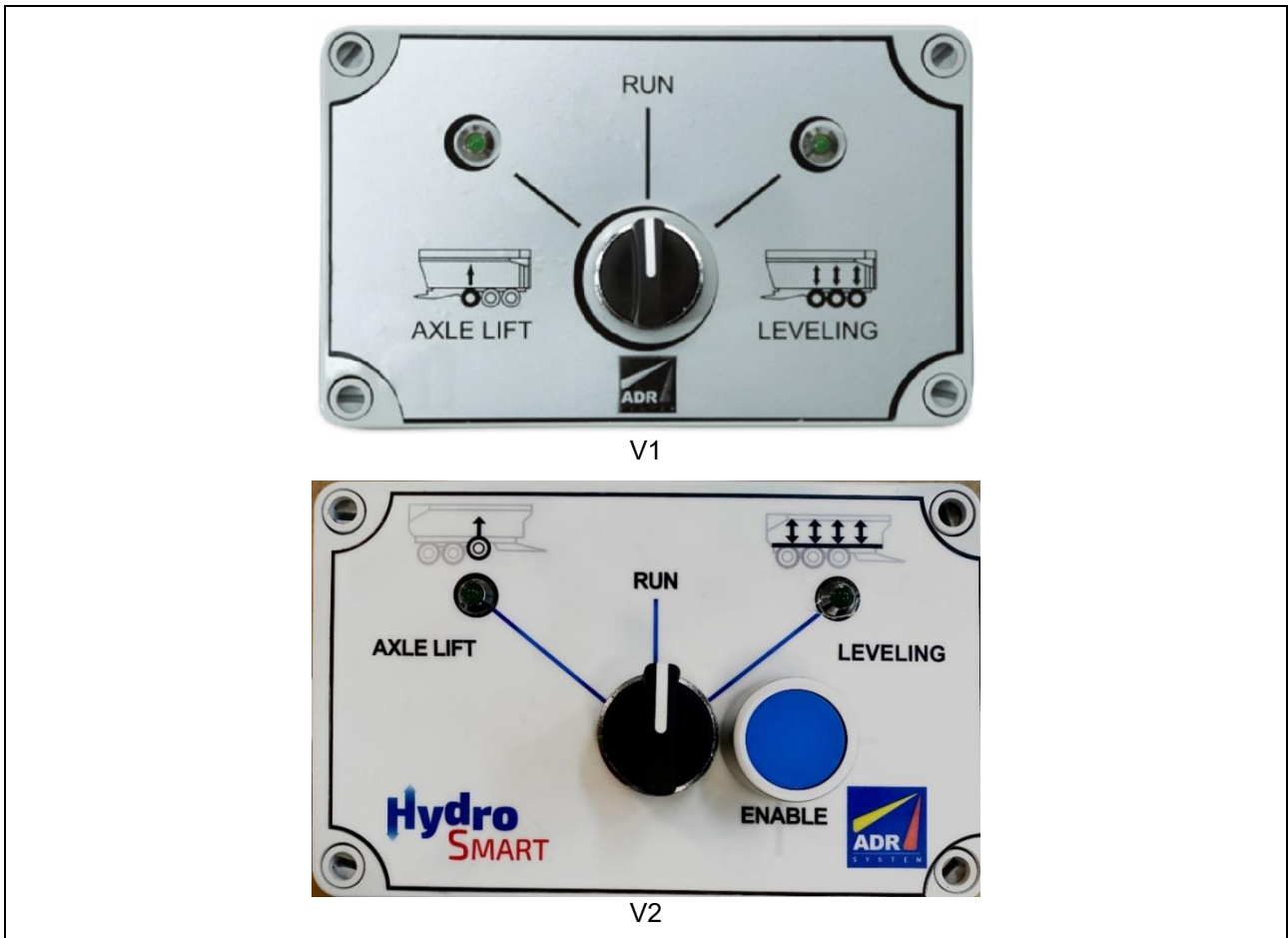

In this condition, referring to the scheme ([chapter 6 Hydraulic diagram](#)):

EV4, EV5 and EV7 are closed (not excited)
EV1 is open (not excited)

On the tractor the joystick must be positioned in the middle (closed circuit of floating and no oil supply)

3.3 Lifting of the axle (mode AXLE LIFT)

The electric switch is positioned on the left, position “AXLE LIFT”

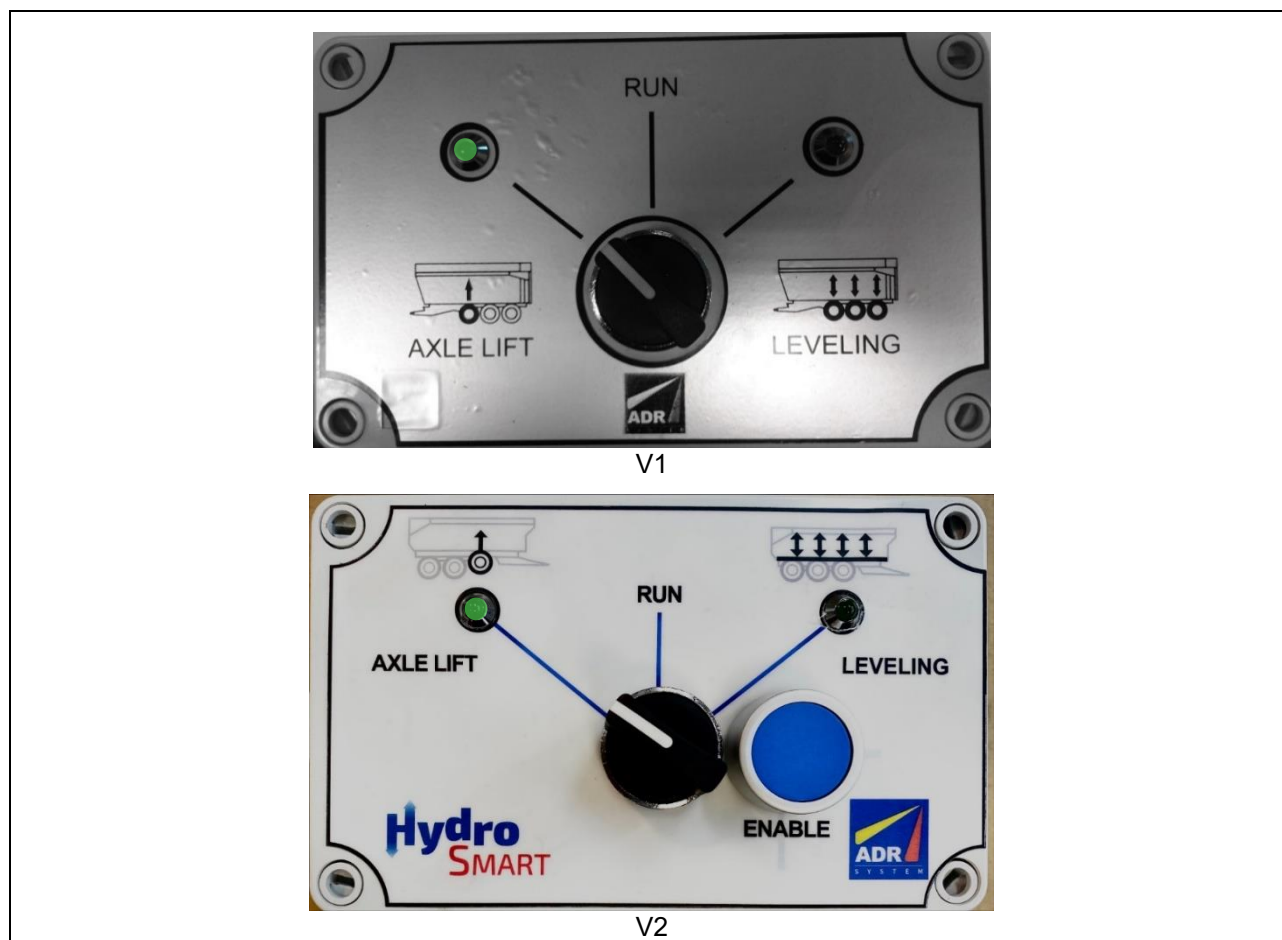

In this condition, referring to the scheme ([chapter 6 Hydraulic diagram](#)):

EV1 is closed (excited);
 EV4, EV5 are closed (not excited);
 EV7 is open (excited).

In this condition the front axle is isolated.

For lifting the front axle: supply oil using the tractor distributor on side A.
 The oil present in the front cylinders is sent to the rear cylinders of the suspension. The whole machine lifts about 1-2 cm.

For lowering again the axle: Put the switch in position “RUN”.
 The machine recovers the original height.

To adjust again the height of the suspension follow the instructions at [chapter 5.3 Leveling of the whole suspension \(mode LEVELING\)](#).

Note: the road circulation with the front axle lifted is not allowed by the law in all the countries.

3.4 Leveling of the whole suspension (mode LEVELING)

The electric switch is positioned on the right, position “LEVELING”



In this condition, referring to the scheme ([chapter 6 Hydraulic diagram](#)):

EV1 is open (not excited)

EV7 is closed (not excited)

EV4 and EV5 are open (excited) (for V2 version only when blue button is pressed is possible to leveling)



Never drive in LEVELING mode neither Load / Unload the trailer in this mode

For lifting the suspension: supply oil using the tractor distributor on side B (and push button on V2 Version).

For lowering the suspension: supply oil using the tractor distributor on side A (and push button on V2 Version).

3.5 Locking of the axles while tipping (only for version 9ZH1E0SA004)

On the version 9ZH1E0SA004 there is one additional valve, code 9ZHYZ38 inserted on the hydraulic circuit for locking the two rear axles. The valve is actioned by the pressure of the dump trailer tipping cylinder.

It allows to block the 2 rear axles simultaneously while tipping. It is activated automatically by the oil line connected to the tipping cylinder.

4 Hydraulic diagrams

4.1 Version 9ZH1E0SA003

The diagrams show the hydraulic connection of the system for the trailer in configuration tandem or tridem.

Hydraulic diagram	Trailer configuration
9ZH1E0SA003-C	tandem
9ZH1E0SA003-E	tridem

Suspension model	Example
Hydro Compact	

4.1.1 Tandem 9ZH1E0SA003-C

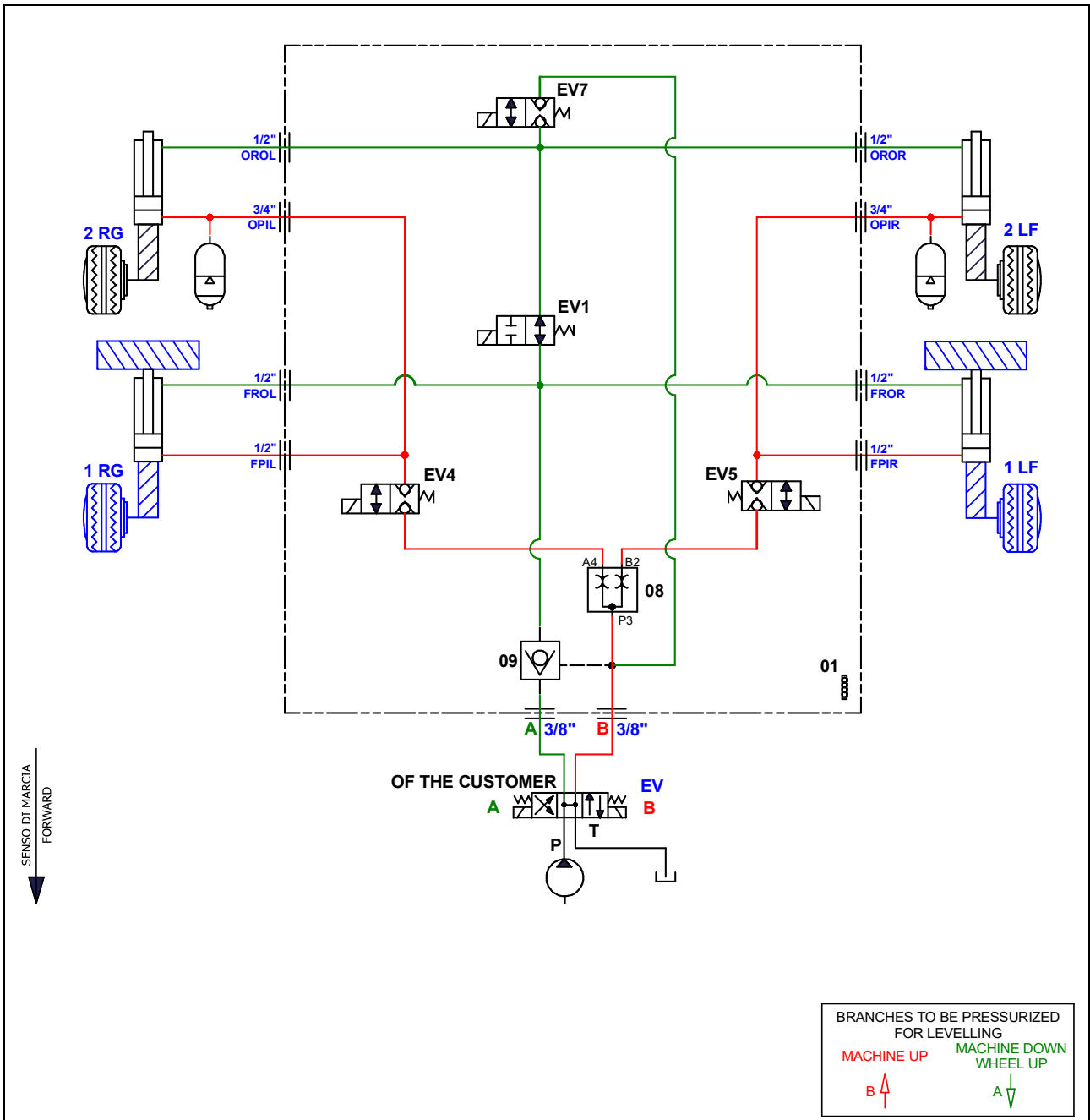

Hydraulic diagram tandem 9ZH1E0SA003-C

Version with front axle lifting.

Valid for suspensions with the cylinder mounted with the chrome rod in upper position.

4.1.2 Tridem 9ZH1E0SA003-E

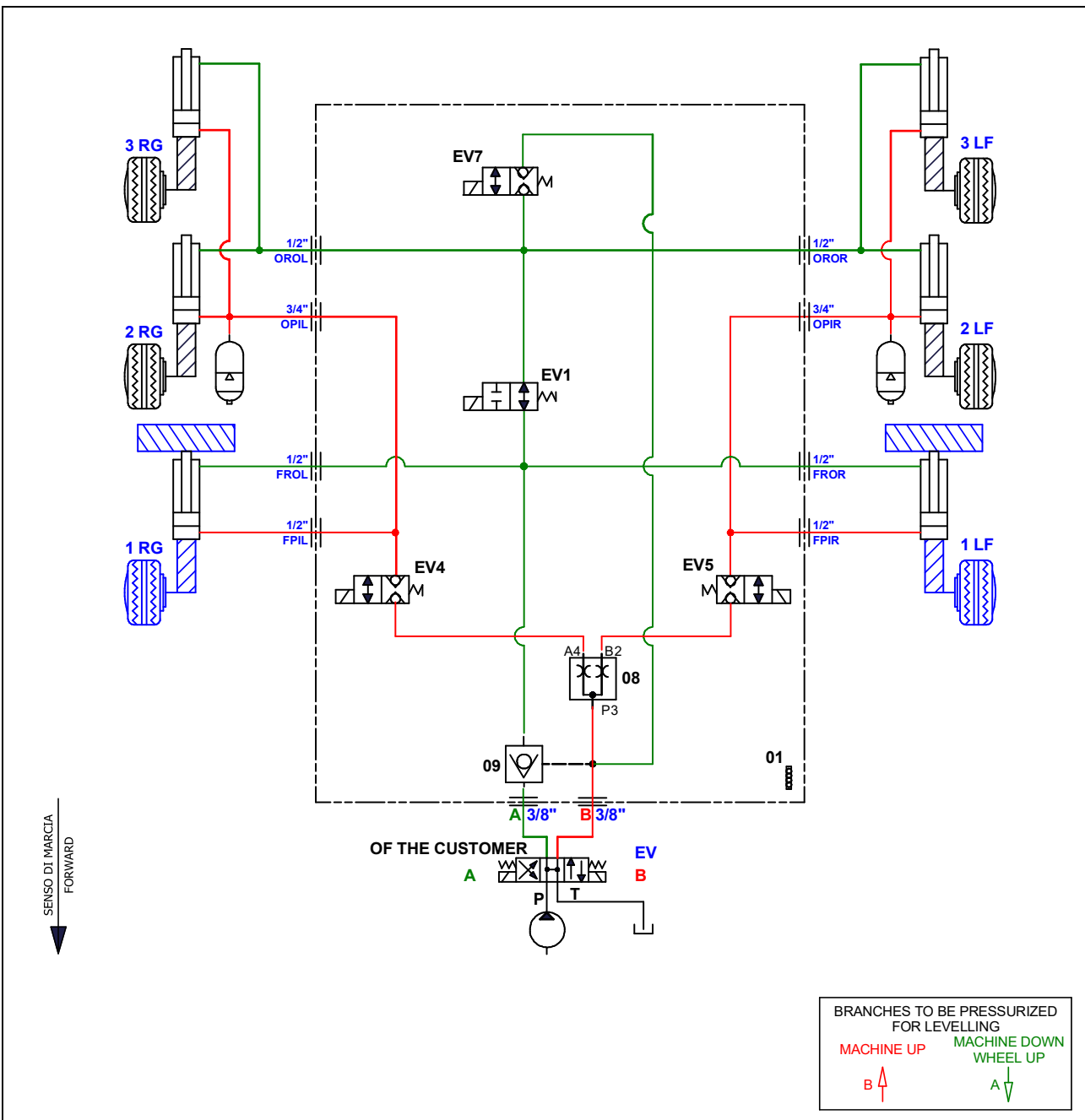

Hydraulic diagram tridem 9ZH1E0SA003-E

Version with front axle lifting.

Valid for suspensions with the cylinder mounted with the chrome rod in upper position.



4.2 Version 9ZH1E0SA004 (with rear axles locking function)

The diagrams show the hydraulic connection of the system for the trailer in configuration tandem or tridem with functionality of rear axle locking for tipping machines.

Hydraulic diagram	Trailer configuration
9ZH1E0SA004-C	tandem
9ZH1E0SA004-E	tridem

Suspension model	Example
Hydro Compact	 A 3D CAD model of a Hydro Compact suspension system. It shows a central horizontal axle with two sets of vertical support structures. Each support structure includes a red hydraulic cylinder and blue metal brackets, designed for mounting on a trailer frame.

4.2.1 Tandem 9ZH1E0SA004-C

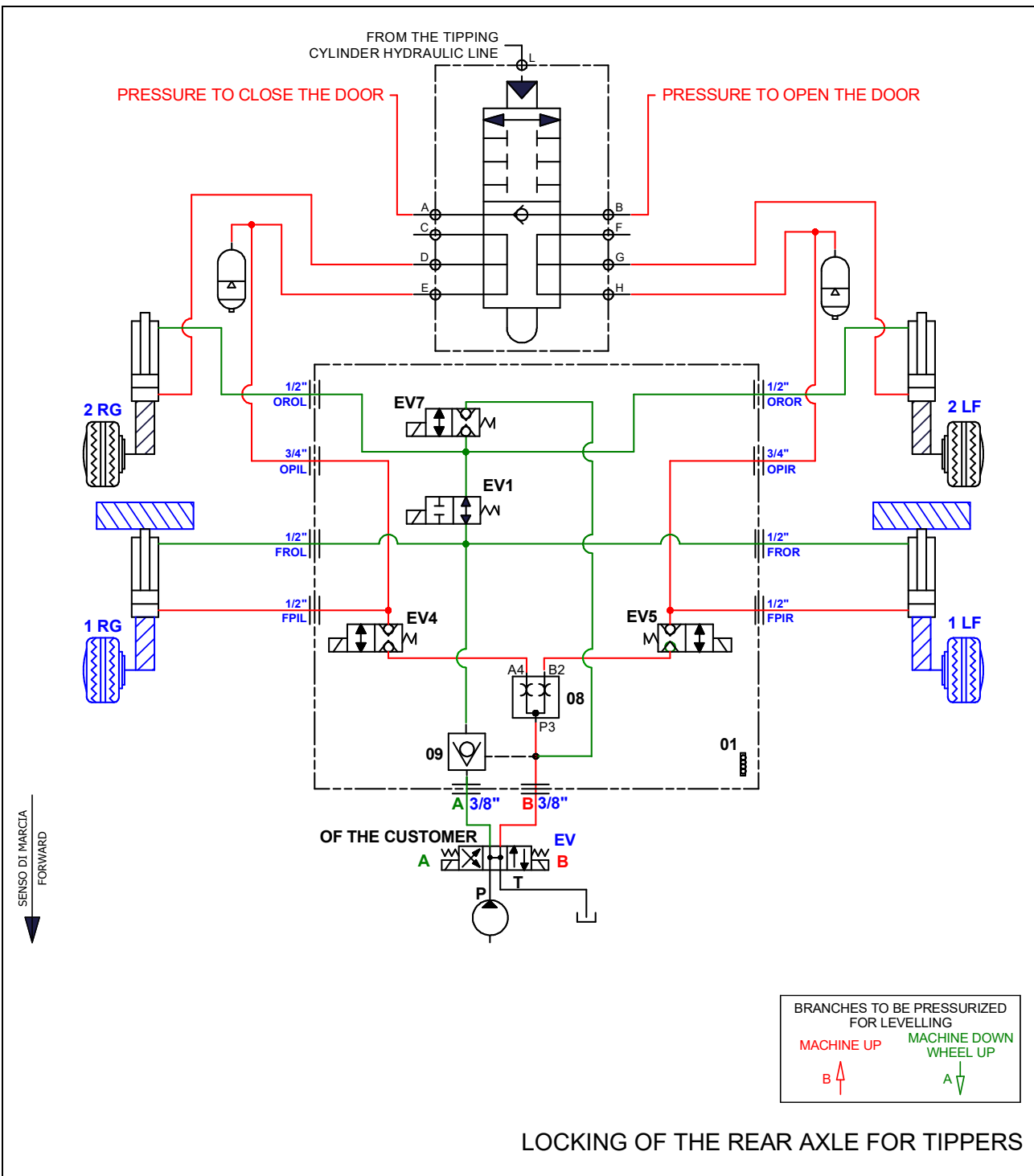

Hydraulic diagram for tandem 9ZH1E0SA004-C

Version with front axle lifting and rear axle locking functionality.
 Valid for suspensions with the cylinder mounted with the chrome rod in upper position.

4.2.2 Tridem 9ZH1E0SA004-E

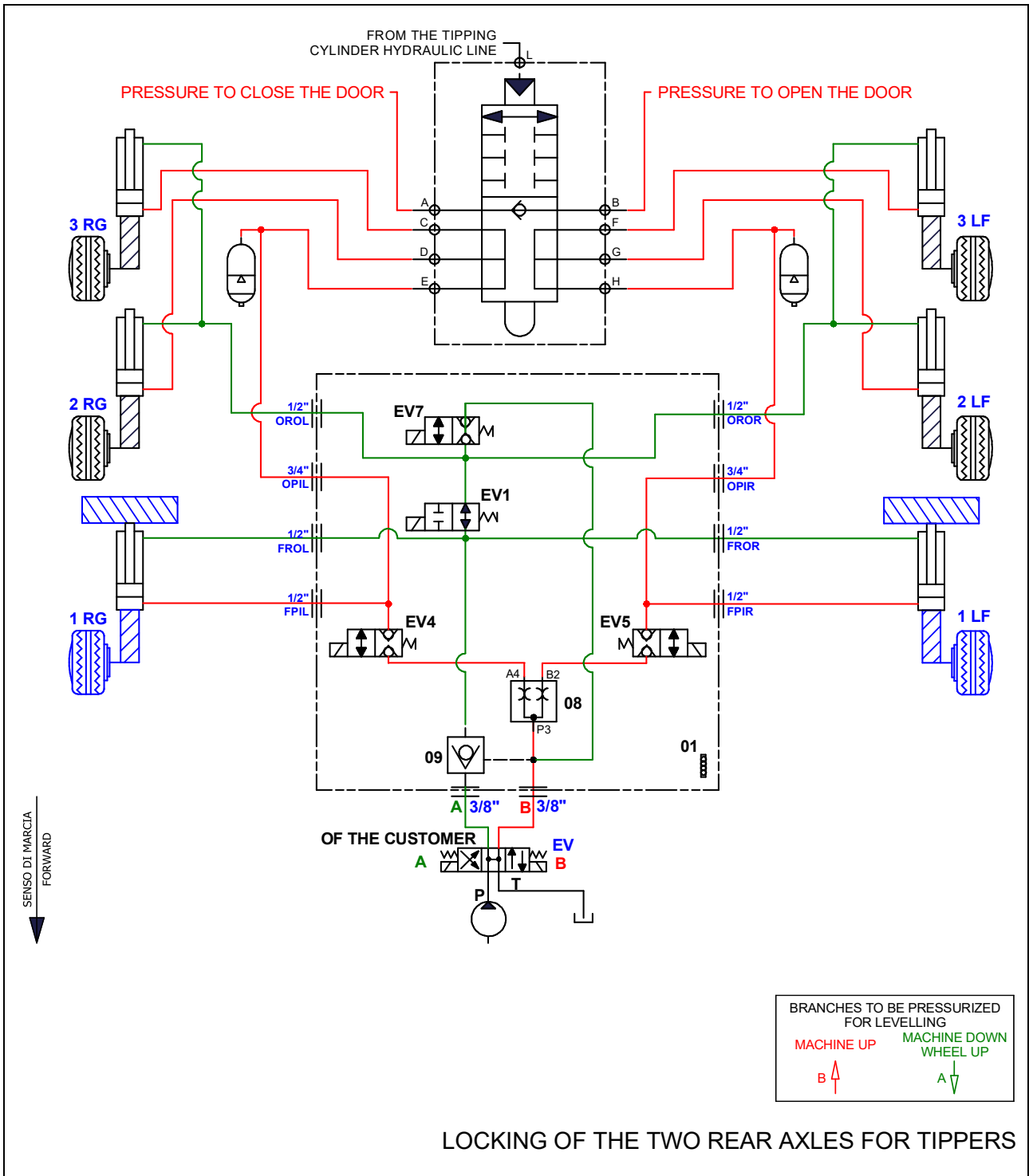

Hydraulic diagram for tridem 9ZH1E0SA004-E

Version with front axle lifting and rear axle locking functionality.
Valid for suspensions with the cylinder mounted with the chrome rod in upper position.





group



www.adraxles.com